

COPY RIGHT NOTES:
 1. THIS DRAWING AND ITS CONTENT IS COPY RIGHT PROTECTED AS AN ARTISTIC WORK (Section 2c), IN TERMS OF THE SA COPY RIGHT ACT No 98 OF 1978, IN ITS ENTIRETY.
 2. THIS DRAWING, ITS CONTENTS AND THE ACTUAL BUILDING IT PORTRAYS, MAY NOT BE ADAPTED, COPIED, DISTRIBUTED, DISTORTED, MODIFIED OR REPRODUCED IN ANY WAY OR FORM BY ANY PARTY, WHICH INCLUDES, BUT IS NOT LIMITED TO CLIENTS, CONSULTANTS OR ANY OTHER OR 3rd PARTIES, WITHOUT THE EXPRESS WRITTEN APPROVAL OF THE AUTHOR(S), BEING MBH ARCHITECTS Pty Ltd OR ANY OF ITS PRINCIPALS (Section 3a&b).
 3. THE ISSUING OF THIS DRAWING BY THE AUTHOR(S), TO ANY PARTY, WHICH INCLUDES, BUT IS NOT LIMITED TO CLIENTS, CONSULTANTS OR ANY OTHER OR 3rd PARTY, SHALL IN NO WAY CONSTITUTE, OR BE CONSTRUED OR IMPLIED TO CONSTITUTE AN EXCLUSIVE LICENSE OR SUB-LICENSE, NOR THE TRANSFER, NOR THE ASSIGNMENT OF COPYRIGHT, TO EXIST BETWEEN THE AUTHOR(S) AND THE PARTY IT IS ISSUED TO, AND SHALL IN NO WAY BE INFERRED BY CONDUCT (Section 22(4)) UNLESS REDUCED TO WRITING (Section 22(3)).
 4. THIS DRAWING AND ITS CONTENT, SHALL BE USED EXCLUSIVELY FOR THE ERRECTING OF THE BUILDING AS PORTRAYED, ON THE BUILDING SITE SO MENTIONED IN THE TITLE BLOCK (Section 15(2)).

ISO 9001 : 2015 COMPLIANT

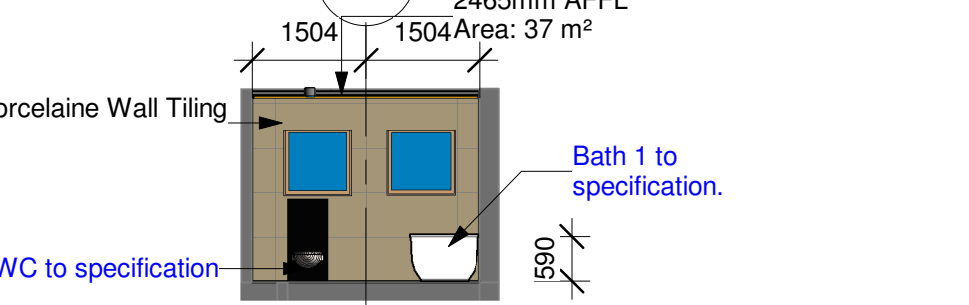

1.1 Ceiling finish to specification
2465mm AFFL
Area: 37 m²
8mm Thick Porcelaine Wall Tiling to spec.
Bath 1 to specification.
WC to specification.

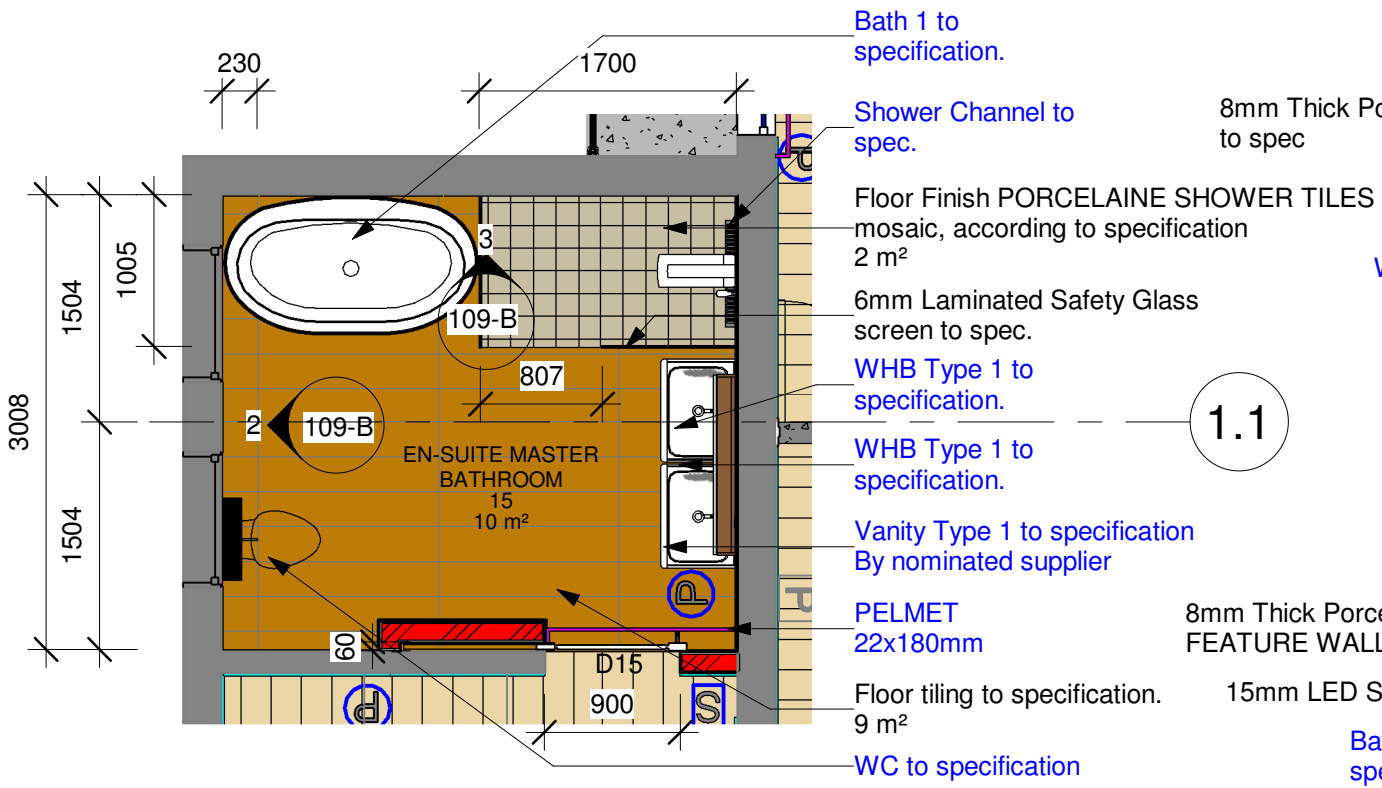
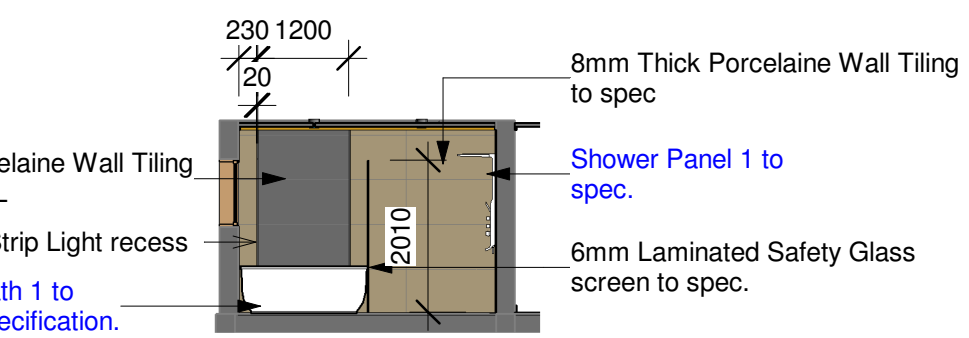

2 1 : 100
8mm Thick Porcelaine Wall Tiling to spec.
Shower Panel 1 to spec.
6mm Laminated Safety Glass screen to spec.
Bath 1 to specification.

1 **FIRST FLOOR - Main En Suite**
1 : 50

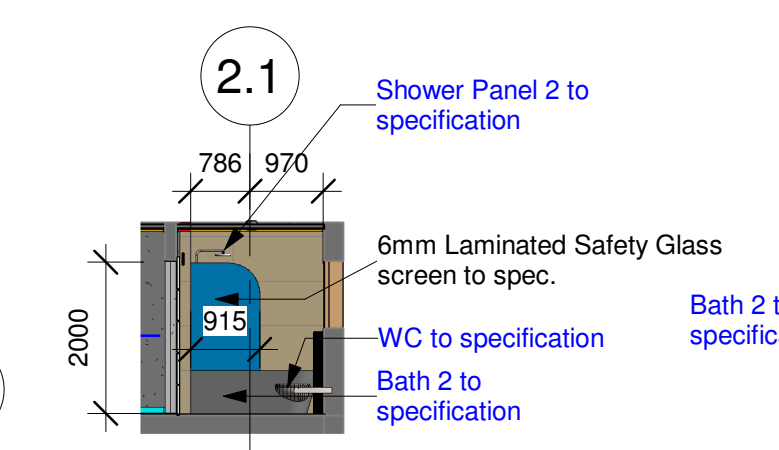
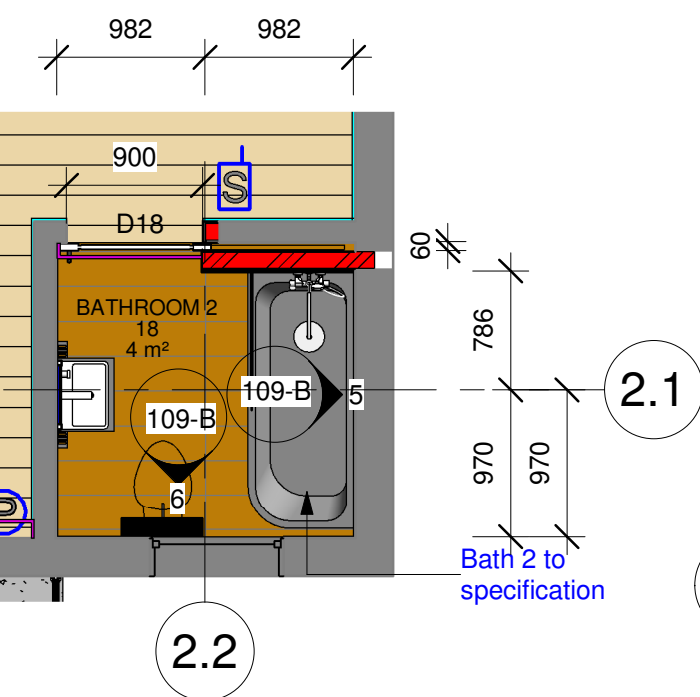

2.1 Shower Panel 2 to specification
6mm Laminated Safety Glass screen to spec.
WC to specification
Bath 2 to specification

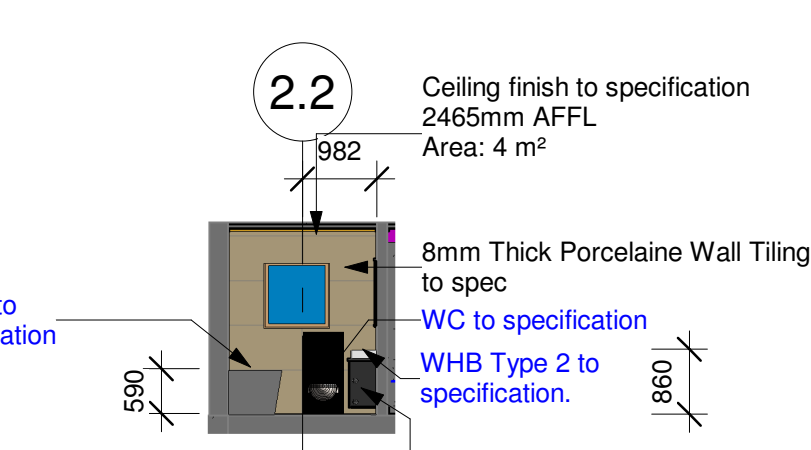

2.2 Ceiling finish to specification
2465mm AFFL
Area: 4 m²
8mm Thick Porcelaine Wall Tiling to spec
WC to specification
WHB Type 2 to specification.
Vanity Type 2 to specification By nominated supplier

4 **FIRST FLOOR - Bathroom 2**
1 : 50

- DEMOLISH EXISTING - - - - -
- EXISTING TO REMAIN - - - - -
- NEW BRICK WORK - - - - -
- NEW DRY WALL - - - - -
- NEW CONCRETE - - - - -
- NEW STEEL - - - - -
- NEW WALL & CORNER PROTECTION - - - - -
- NEW BARIUM PLASTER - - - - -

No.	Description	Date

ISSUED FOR CONSTRUCTION
mbh International Sp. z o.o.

POLAND, EU
 Architects, Interior & Industrial Designers
 +48 533 942 111 mbh.international.pl@gmail.com
 www.mbh-architects.com

LEVEL 1 B-BBEE Contributor
mbh Architects (Pty) Ltd

SOUTH AFRICA
 Architects, Interior Designers & Industrial Designers
 +27 83 406 4988 - mbharchitectssa@gmail.com
 www.mbh-architects.com

CLIENT NAME
Mr Franz Rossbacher

PROJECT NAME and ADDRESS
**House Rossbacher, 882
 Carlswald North Estate**

DRAWING NAME
BATHROOM DETAILS 1 & 2

Drawing Issue Date **21 APRIL 2025**

Project Architect **M HEUNIS**

SACAP Reg No **20695**

Drawn by **BH**

DRAWING NUMBER
 SHEET No-STOREY-BUILDING-UNIT-SECTION-DISCIPLINE-WORK STAGE REVISION No
109-B

PROJECT No
RES 25-04

As indicated Sheet Size **A3**

NOTE : LOOSE FURNITURE & EQUIPMENT IS SHOWN FOR ILLUSTRATION PURPOSES ONLY. THIS DOES NOT FORM PART OF THE BUILDING PROJECT, UNLESS SPECIFIED.

2025/06/02 10:42:16 AM